

P&R

INSTRUMENT SUPPLY, INC.



PC-10K

Hydraulic Pressure Comparator/Calibrator

- Low cost alternative to weight systems
- Self contained
- Ease of operation
- Water or oil operated (do not use deionized water)
- Spare seal kit
- 1/4-18 NPT and 1/2-14 NPT adapters
- Set of wrenches for mounting and unmounting gauges

Accessories

- Additional spare seal kit
- Spare reservoir

■ Operational Description

Ideal for Pressure Gauge Calibration

The PC-10K is a self contained pressure generator that allows comparison of a known pressure as displayed on the master gauge to the display of the pressure sensor under test, attached to the calibrate port.

The PC-10K is capable of generating pressures up to 10,000 psi by rotating the three handled piston drive screw. A fine adjustment knob is included to provide higher resolution.

■ Applications

The PC-10K provides a low cost, portable, easy to operate method of calibration and or pressure generation for the user of large quantities of analog gauges and pressure transducers that require periodic verification of their accuracy. The full scale is changeable depending on the range of the master digital gauge installed on the front or standard port.

P&R INSTRUMENT SUPPLY, INC.
2668 WOOD HOLLOW DR.
ATLANTA, GA 30360

tollfree: 800-622-9555
local: 770-391-9117
fax: 770-395-6346

www.prinstrument.com
sales@prinstrument.com

P&R INSTRUMENT SUPPLY, INC.

■ Hydraulic Comparator Specifications

| | |
|--------------------|---|
| Performance | |
| Max Pressure: | 10,000 psi |
| Min Pressure: | 5 psi |
| Burst Pressure: | > 12,000 psi |
| Weight: | 22 lb. (10 kg) |
| Materials | |
| Ram/Adaptors: | 15-5 SS |
| Body: | Anodize Aluminum |
| O-Rings: | Buna N/Nitrile |
| Test Media: | Water or light oil (do not use deionized water) |
| Accessories | |
| Adaptors: | 1/4-18 and 1/2-14 NPT standard |
| Wrenches: | Included |

Specifications are subject to change without notice.

■ Dimensions — In./mm

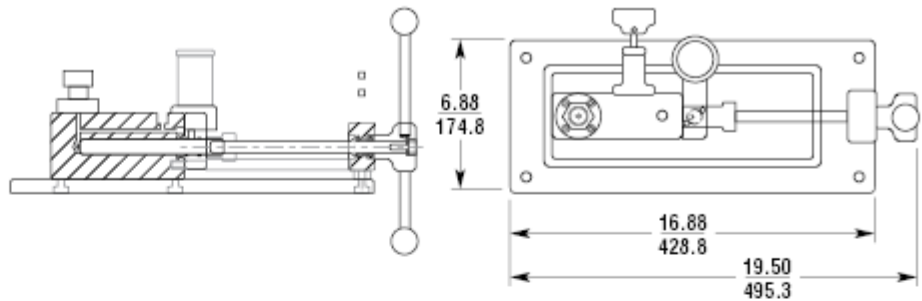

■ Ordering Information

To order this unit, please use model number: **PC-10K-NG**.

Master Gauge

To order a master gauge, please refer to the PG-5000 datasheet and order as a separate item.

Accessories

Please order separately, by part number.

| Description | Part Number |
|----------------------------------|-----------------|
| Spare seal kit – blue body style | 511408 |
| Spare seal kit – gold body style | 511501 |
| Spare seal kit – gray body style | 511501 & 511502 |
| Spare reservoir | 511405 |

P&R INSTRUMENT SUPPLY, INC.
2668 WOOD HOLLOW DR.
ATLANTA, GA 30360

tollfree: 800-622-9555
local: 770-391-9117
fax: 770-395-6346

www.prinstrument.com
sales@prinstrument.com